

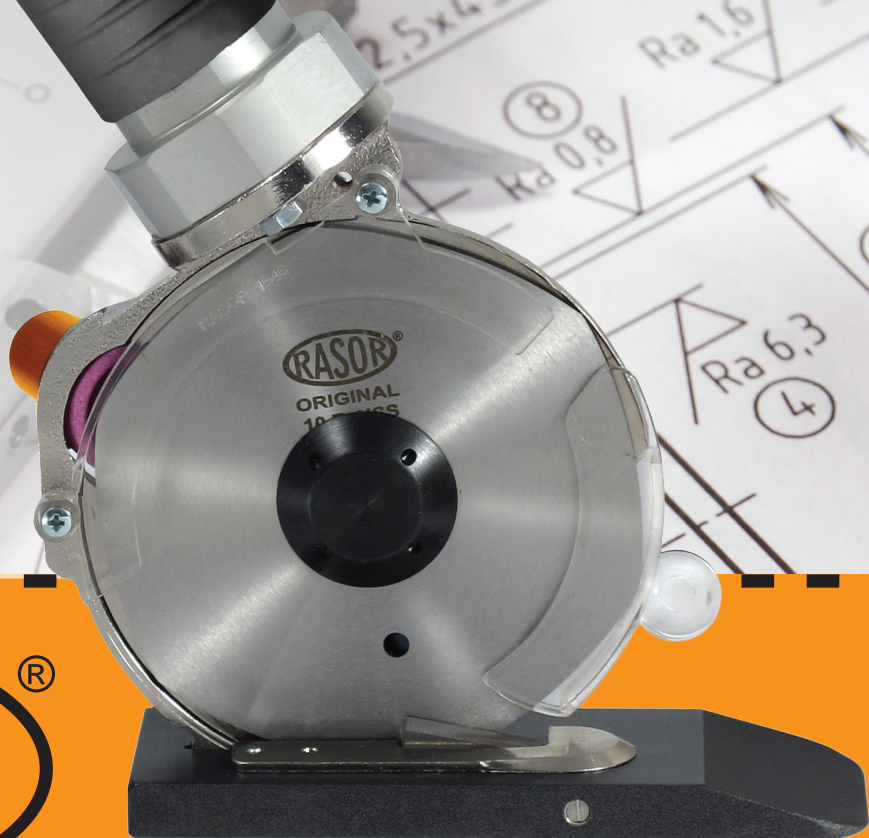

SRS AIRBAG

AVAILABLE IN
RIGHT VERSION
FP100



1946

FP100L PNEUMATIC CUTTING UNIT

FP100L. Professional High-Performance pneumatic cutting unit
for Textile & Technical Textile applications.



1946

WHAT'S NEW:

- Central back-located air exhaust
- +10% power
- +10% torque
- Low-friction Teflon® coated foot
- Easy fixing structure for O.E.M applications

TECHNICAL DETAILS:

- Blade diameter:** 100 mm (4"), with hard metal counterblade
- Blade equipped:** 10EHSS, 6-edges, HSS steel
- Blade speed:** 900 r.p.m.*
- Cutting ability:** up to 35 mm (1.4")
- Power:** 400 W (at nominal air supply conditions*)
- Operating pressure:** 6 bar nominal* (± 1 bar) lubricated air supply
- Air consumption:** 9 l/sec*
- Net weight:** 1350 g
- Total weight (with packing box):** 3050 g
- Sound pressure:** 72 dBe (EN ISO 15744)*
- Vibration Level:** 1,36 m/sec² (ISO 8662)*
- Minimum brightness for working operations:** LUX 200
- Temperature range:** 0 – 55 C
- Umidity range:** 10 – 95% without condensate

*The reported data are collected at a pressure of 6 bar (ISO 2787: 1984), recommended operating pressure.

PNEUMATIC CUTTING UNIT FP100L

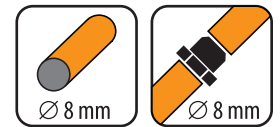
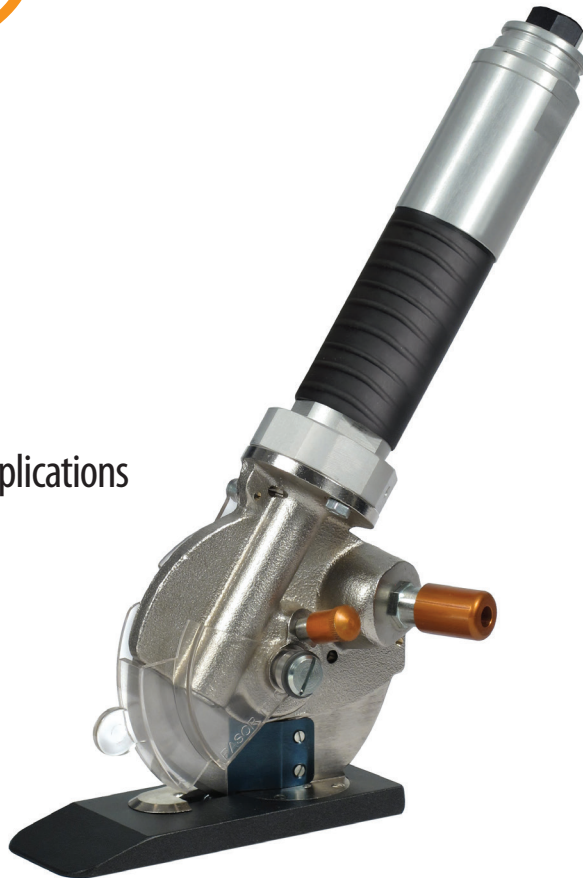

minimum recommended



Rasor recommend to use only dry air lubricated with special Rasor VG 10 pneumatic oil

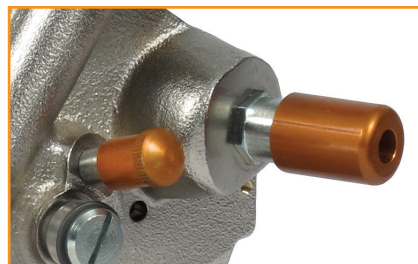

Sharpening device

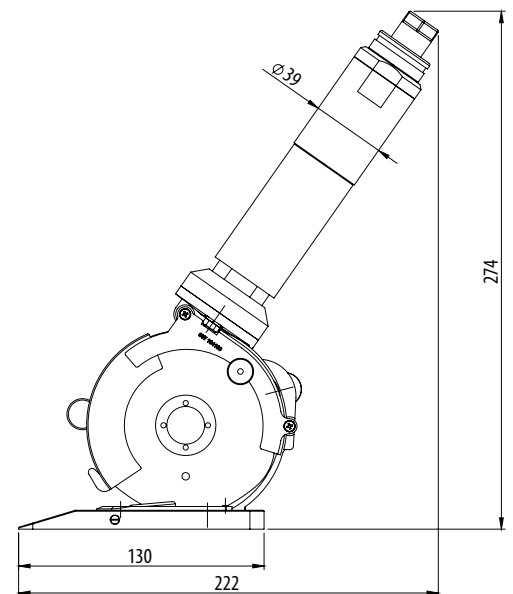

Dimension layout

BLADES AVAILABLE:

- 10EHSS**, 100 mm 6-edges, HSS steel
- 10SEXTG**, 100 mm 4-edges, EXTRA steel
- 10CSW**, 100 mm circular, HSS steel
- 10EHSSTF**, 100 mm 6-edges, HSS steel Teflon® coated
- 10EMD**, 100 mm 6-edges, Carbide (Widia®)



PETRONI SRL
Via A.Bucchi, 1/B
06012 Città di Castello (PG)
+39 075/852.07.87
www.petronisrl.it